

GENERAL NOTES

1. THE GENERAL CONTRACTOR SHALL PROVIDE A PROPER AND SUITABLE HOISTWAY ENCLOSURE, THAT SHALL BE CONSISTANT WITH BUILDING CONSTRUCTION AND MEET THE MINIMUM LOAD BEARING FACTORS SHOWN.
2. THE GENERAL CONTRACTOR SHALL PROVIDE A MIN. OF A 24" DEEP RECESS PIT AREA.
3. THE GENERAL CONTRACTOR SHALL PROVIDE A PROPER AREA FOR INSTALLATION OF PUMPING UNIT AND CONTROLLER, WITH A 120 VAC CONVENIENCE OUTLET, LIGHT AND LIGHT SWITCH.
4. HOISTWAY WALLS MUST BE SET PLUMB AND SQUARE 1/16" IN ALL DIRECTIONS.
5. THE GENERAL CONTRACTOR SHALL PROVIDE AND INSTALL DOORS, FRAMES AND CLOSER, INCLUDING ADEQUATE VENTILATION FROM OUTSIDE OF BUILDING TO ELEVATOR ENCLOSURE.
6. THE GENERAL CONTRACTOR SHALL PROVIDE CONNECTION OF TELEPHONE TRAVELING CABLE TO OUTSIDE CENTRAL EXCHANGE AS REQUIRED BY ANSI A17.1 CODE.
7. ELECTRICAL CONTRACTOR SHALL PROVIDE 230 VOLT, 1 PHASE, 60 HZ, WITH MANUAL FUSED DISCONNECT WITH AUXILIARY CONTACTS FOR BATTERY LOWERING, POWER FEED TO CONTROL PANEL, AND 110/115 VAC LIGHT AND DUPLEX RECEPTACLE IN MACHINE AREA.
8. A SEPERATE 120 VAC, 15 AMP., SINGLE PHASE POWER SUPPLY WITH A FUSED, LOCKABLE SWITCH OR CIRCUIT POWER BREAKER, MUST BE PROVIDED AND BROUGHT TO THE CONTROLLER FOR THE CAR LIGHTS.
9. AN OUTSIDE TELEPHONE LINE MUST BE PROVIDED AND BROUGHT TO THE CONTROLLER.

REV NO.	BY	DESCRIPTION	DATE
1	.	.	.
2	.	.	.
3	.	.	.
4	.	.	.

GENERAL DATA	
CAPACITY	1400 LBS.
GROSS LOAD	2550 LBS.
LOAD ON BUFFERS	5600
SPEED	30 FPM UP, 30 FPM DOWN
TRAVEL	11'-11"
STOPS	2
OPENINGS	2
TOTAL RAIL LENGTH	22'-1"
RAIL SECTIONS	2@ 96", & 1@ 73"
FIRE SERVICE	N/A
LOBBY/ALT. FLOOR	N/A
OVER TRAVEL	3"
UNDER TRAVEL	3"
WORKING PSI	720 LBS.

MACHINE ROOM ADJACENT AT SECOND LEVEL

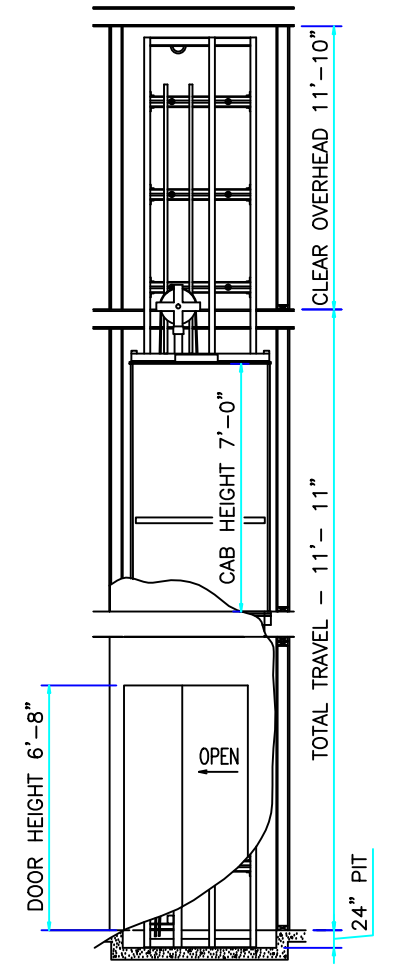
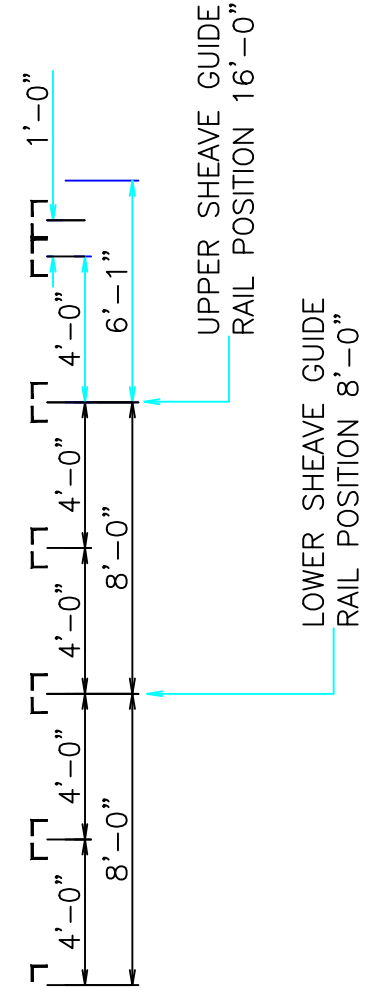
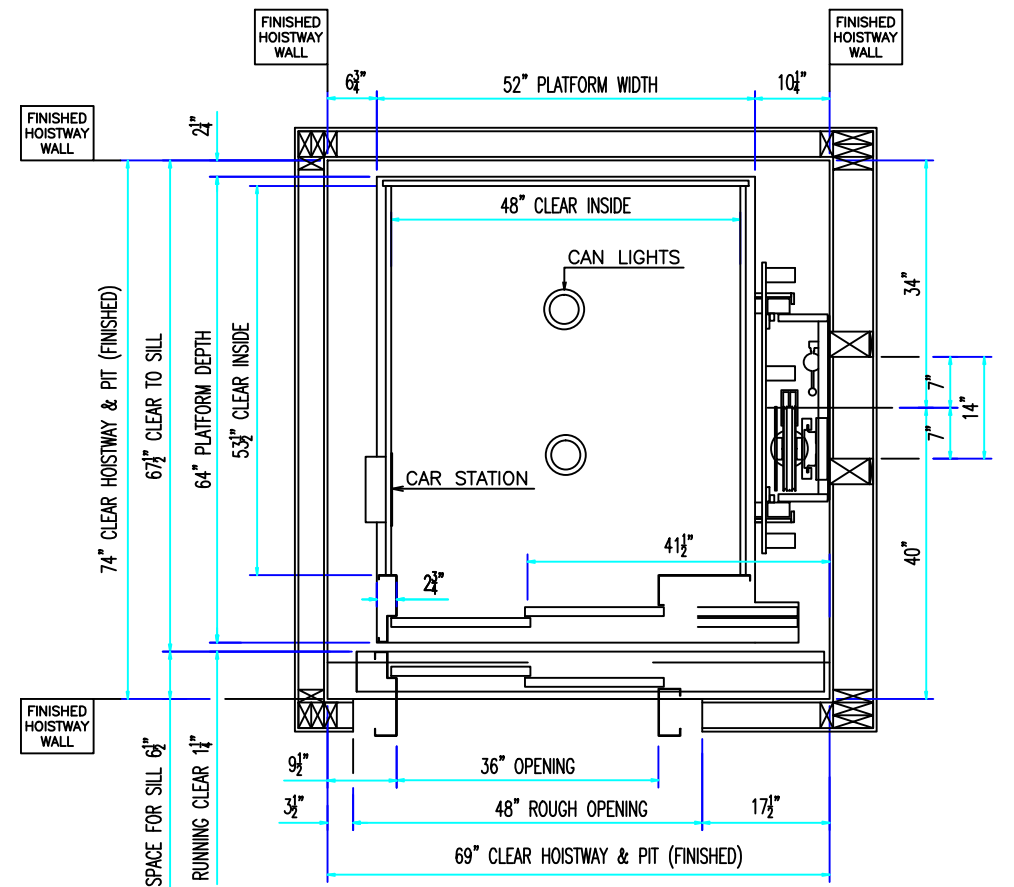

NOTE:
MINIMUM 4" THICK REINFORCED CONCRETE PIT FLOOR
HOISTWAY FRONT VIEW

MACHINERY & POWER	
MACHINE	ROPED HYDRAULIC 3 1/2" PISTON
MACHINE LOCATION	LOWEST LANDING RAIL ADJACENT
PUMP EQUIPMENT	5HP MOTOR 20-56 PUMP
POWER SUPPLY	230 VAC, 1 PHASE, 60 HZ
DISCONNECT	30 AMP, 3 POLE
3 1/2" PLUNGER	.313 WALL
5 5/8" CYLINDER	SCH. 40 A106
PISTON LENGTH	7'- 2.5"
CYLINDER LENGTH	6'- 6"
OIL LINE	1/2" SCHEDULE 80

FEATURES	
PLATFORM SIZE	52" X 64"
CLEAR INSIDE	48" X 53.5"

SPECIAL ITEMS	
RESCUVATOR	XXXXXXXXXX
	XXXXXXXXXX
	XXXXXXXXXX

American Crescent Elevator

THIS ARRANGEMENT AND SUPPLEMENTAL NOTES:

APPROVED NO EXCEPTIONS
 APPROVED AS NOTED
 REVISE AND RESUBMIT

Signature _____
 Date _____

The PRELIMINARY SHOP DRAWINGS are provided for your review & verification of specific features of the elevator & building. Equipment will be processed only AFTER these drawings are returned to American Crescent Elevator, with ALL information verified and all color selections are made, complete with signature. Actual ship dates from the factory will be confirmed to you after the approved prints are received. If you have any questions about any of the information or need assistance in completing your review, please contact: American Crescent at (601) 798-9392.

The FINAL SHOP DRAWINGS reflect all modifications/clarifications as indicated on the Preliminary Drawings and should be referenced carefully during construction and preparation for elevator installation. Any deviation from the information or dimensions contained herein could have a serious effect on the elevator installation and/or operation of the elevator. Any increase of size or addition of items may be subject to a price adjustment and can contribute to a longer lead time on equipment.

PROJECT: Lakeshore Baptist
 JOB NO.: 9392-XXXX
 DESCRIPTION: ELEVATOR SPECIFICATIONS
 Drawn By ACP | Scale N.T.S. | Date 10/25/2013 | Sheet 1 OF 4

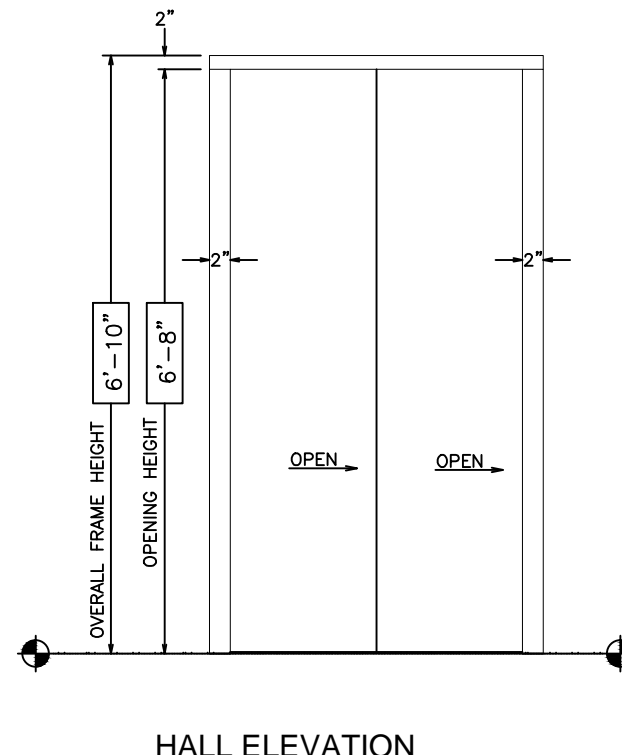
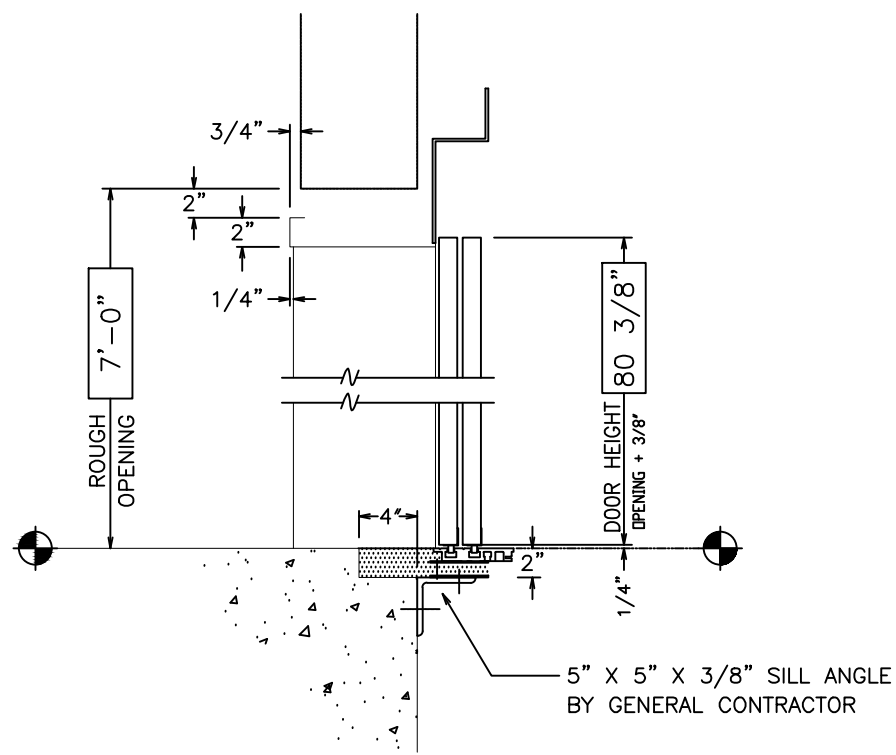

	OPERATOR	TEMPLATE
<input checked="" type="checkbox"/>	G.A.L.	8242
<input type="checkbox"/>	M.A.C.	.

	LANDINGS	FLOOR TRAVEL
<input type="checkbox"/>	XXXXXX	.
<input type="checkbox"/>	XXXXXX	.
<input type="checkbox"/>	XXXXXX	.
<input type="checkbox"/>	XXXXXX	.
<input type="checkbox"/>	XXXXXX	.
<input type="checkbox"/>	XXXXXX	.
<input checked="" type="checkbox"/>	1ST TO 2ND	11'-11"
	PIT	24"

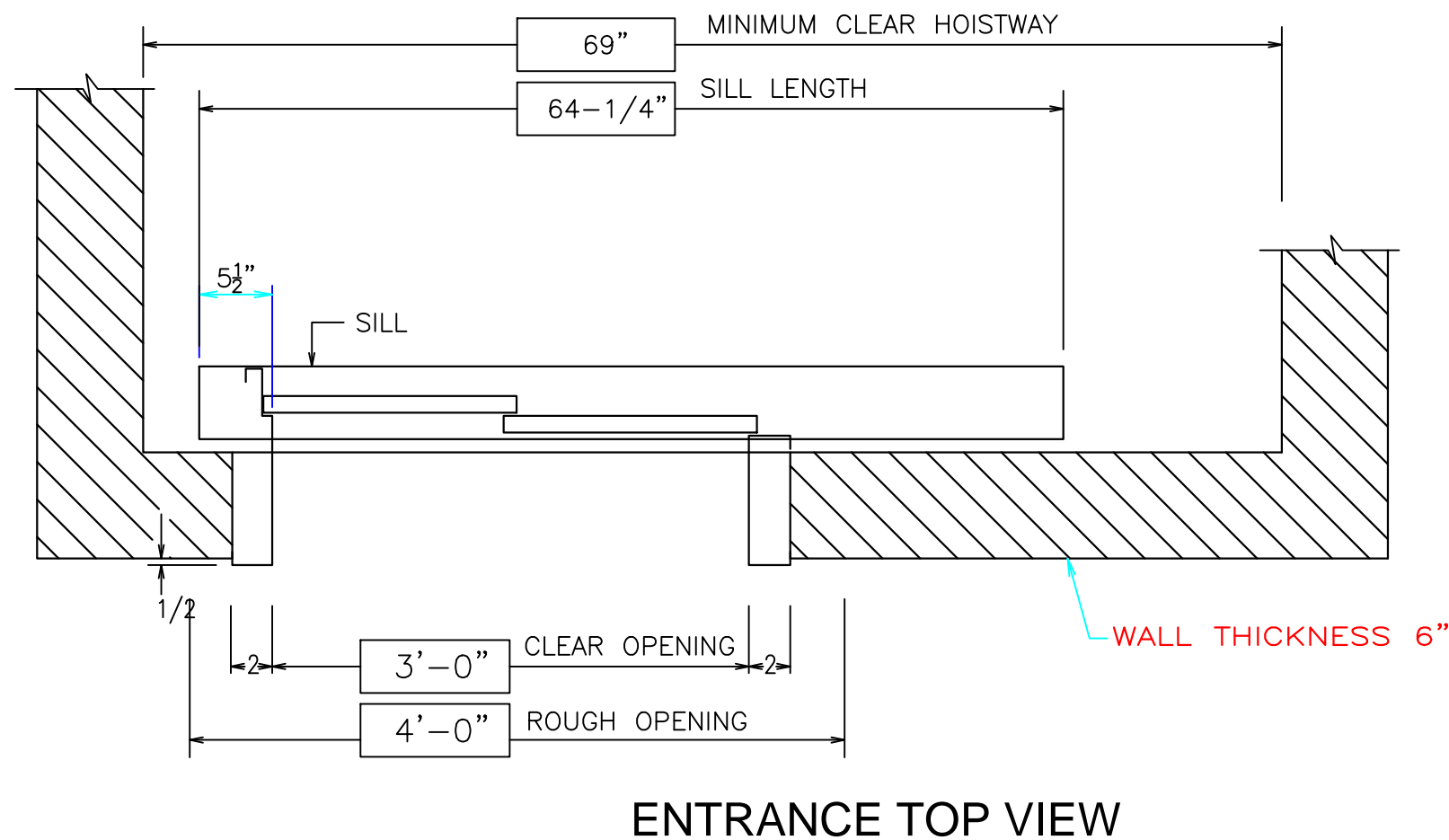

REV NO.	BY	DESCRIPTION	DATE
1	.	.	.
2	.	.	.
3	.	.	.

FRONT ENTRANCE SPECIFICATION	
NUMBER OF OPENINGS	2
TYPE OF ENTRANCE	2 SPEED
OPENING SIZE	36" X 80"
HAND OF DOOR	LEFT
ENTRANCE FRAME FINISH	#4 STN/STL
ENTRANCE DOOR FINISH	#4 STN/STL
ENTRANCE SILL FINISH	CLEAR ALUMINUM
WALL THICKNESS	6"
WALL TYPE	BLOCK <input type="checkbox"/> DRYWALL <input checked="" type="checkbox"/>
REAR ENTRANCE SPECIFICATION	
NUMBER OF OPENINGS	.
TYPE OF ENTRANCE	.
OPENING SIZE	.
HAND OF DOOR	.
ENTRANCE FRAME FINISH	.
ENTRANCE DOOR FINISH	.
ENTRANCE SILL FINISH	.
WALL THICKNESS	.
WALL TYPE	BLOCK <input type="checkbox"/> DRYWALL <input type="checkbox"/> OTHER <input type="checkbox"/>
DOOR DRILLING INFORMATION	
OPERATOR MFG BY	GAL

American Crescent Elevator

THIS ARRANGEMENT AND SUPPLEMENTAL NOTES:

APPROVED NO EXCEPTIONS
 APPROVED AS NOTED
 REVISE AND RESUBMIT

Signature _____
 Date _____

The PRELIMINARY SHOP DRAWINGS are provided for your review & verification of specific features of the elevator & building. Equipment will be processed only AFTER these drawings are returned to American Crescent Elevator, with ALL information verified and all color selections are made, complete with signature. Actual ship dates from the factory will be confirmed to you after the approved prints are received. If you have any questions about any of the information or need assistance in completing your review, please contact: American Crescent at (601) 798-9392.

The FINAL SHOP DRAWINGS reflect all modifications/clarifications as indicated on the Preliminary Drawings and should be referenced carefully during construction and preparation for elevator installation. Any deviation from the information or dimensions contained herein could have a serious effect on the elevator installation and/or operation of the elevator. Any increase of size or addition of items may be subject to a price adjustment and can contribute to a longer lead time on equipment.

PROJECT: Lakeshore Baptist
 JOB NO.: 9392-XXXX
 DESCRIPTION: ELEVATOR ENTRANCE
 Drawn By ACP | Scale N.T.S. | Date 10/25/2013 | Sheet 2 OF 4

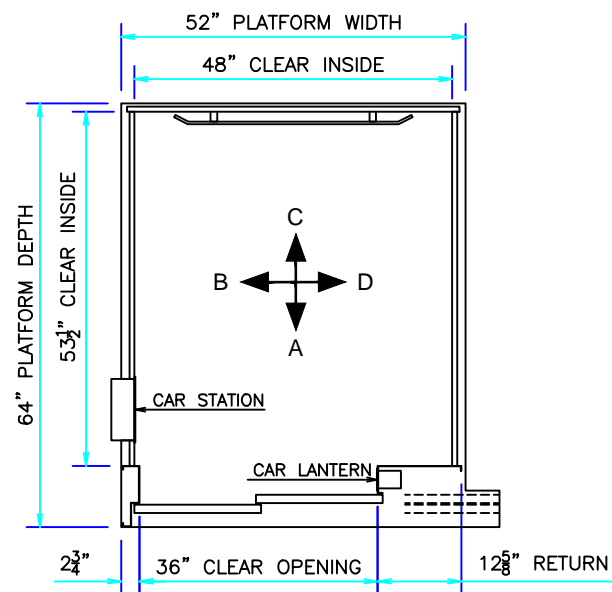

PLAN VIEW

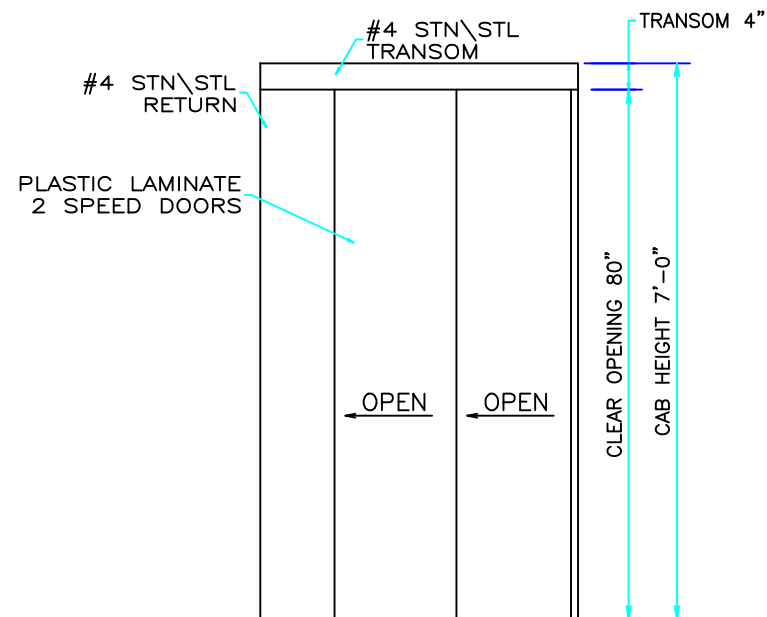

ELEVATION A

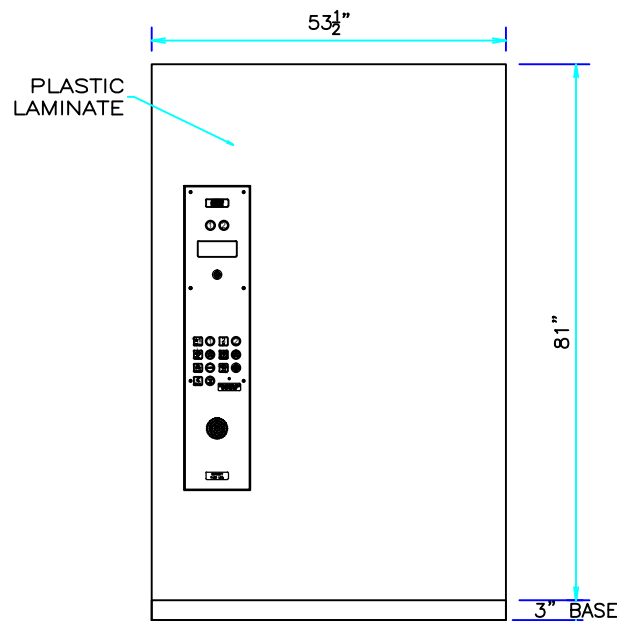

ELEVATION B

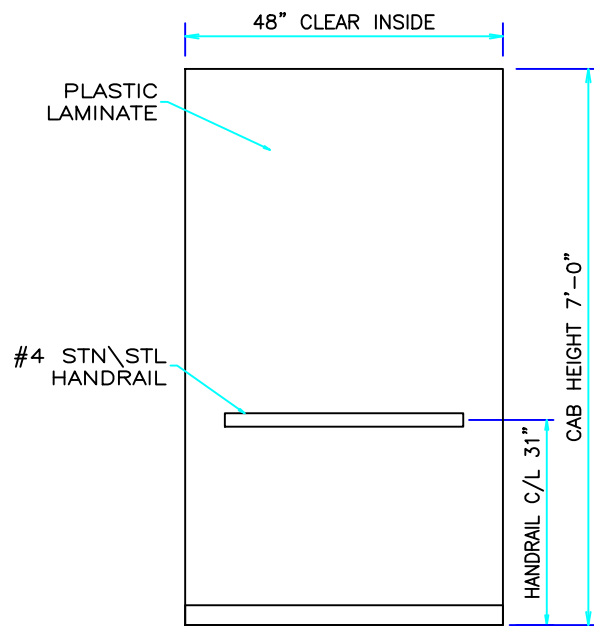

ELEVATION C

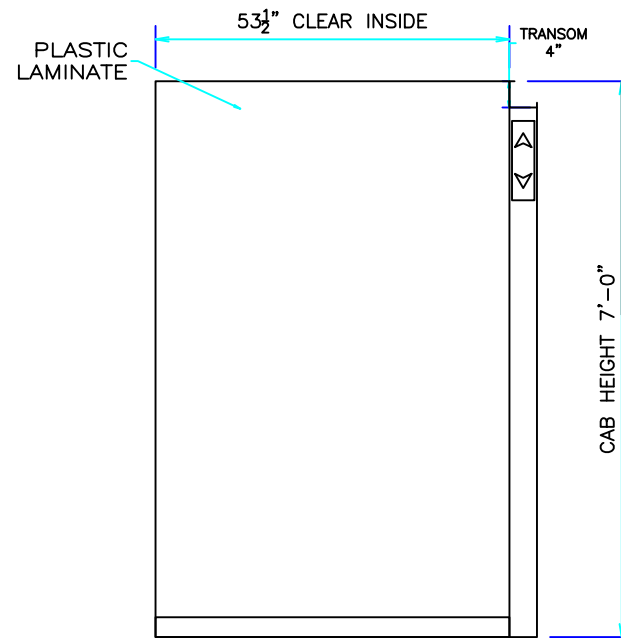

ELEVATION D

REV NO.	BY	DESCRIPTION	DATE
1	.	.	.
2	.	.	.
3	.	.	.
CAB FINISHES			
CAB MODEL	TRADITIONAL		
CAB STYLE	A		
WALL FINISH	LAMINATE-- PLEASE VERIFY SELECTION		
TRIM FINISH	#4 STN/STL		
BASES	#4 STN/STL		
CAB HEIGHT	7'-0"		
CAR FRONTS	#4 STN/STL		
CEILING	WHITE MELAMINE		
GATE/DOOR TYPE	2 SPEED		
GATE/DOOR SIZE	36" X 80"		
GATE/DOOR FINISH	#4 STN/STL		
GATE/DOOR OPERATION	GAL MOVFR		
LIGHTING	(2) RECESSED CAN LIGHTS		
HANDRAIL	(1) #4 STN/STL		
DOOR SILL	CLEAR ALUMINUM		
VENTILATION	N/A		
DOOR RE-OPENING	INFERED DETECTORS		
FLOORING	BY OTHERS		

THIS ARRANGEMENT AND SUPPLEMENTAL NOTES:

- APPROVED NO EXCEPTIONS
- APPROVED AS NOTED
- REVISE AND RESUBMIT

Signature _____

Date _____

The PRELIMINARY SHOP DRAWINGS are provided for your review & verification of specific features of the elevator & building. Equipment will be processed only AFTER these drawings are returned to American Crescent Elevator, with ALL information verified and all color selections are made, complete with signature. Actual ship dates from the factory will be confirmed to you after the approved prints are received. If you have any questions about any of the information or need assistance in completing your review, please contact: American Crescent at (601) 798-9392.

The FINAL SHOP DRAWINGS reflect all modifications/clarifications as indicated on the Preliminary Drawings and should be referenced carefully during construction and preparation for elevator installation. Any deviation from the information or dimensions contained herein could have a serious effect on the elevator installation and/or operation of the elevator. Any increase of size or addition of items may be subject to a price adjustment and can contribute to a longer lead time on equipment.

American Crescent Elevator

PROJECT: Lakeshore Baptist

JOB NO.: 9392-XXXX

DESCRIPTION: CAB DETAILS

Drawn By ACP Scale N.T.S. Date 10/25/2013 Sheet 3 OF 4

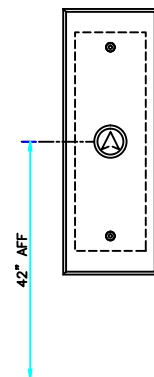
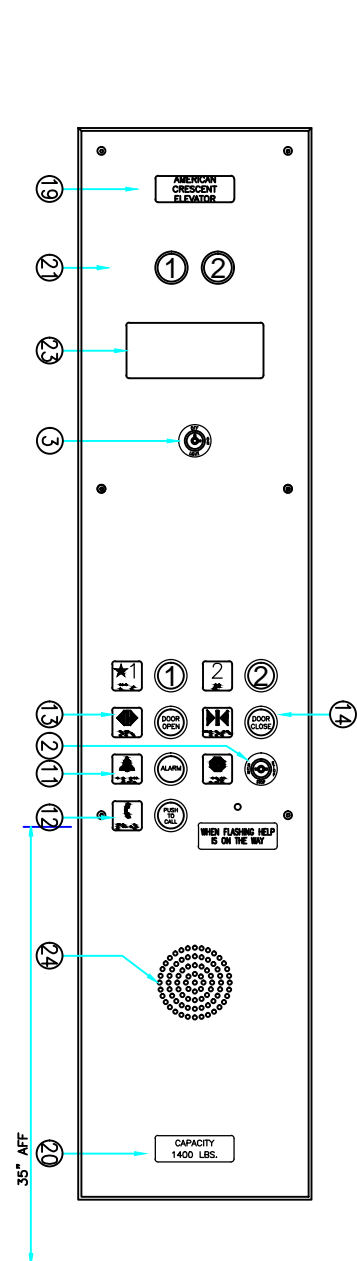

TERMINAL HALL STATION
FINISH: #4 STN\STL
BOX DEPTH 3 1/2"
QUANTITY: 1

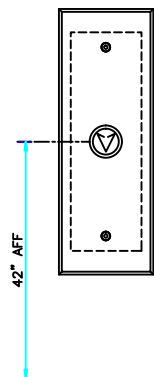

TERMINAL HALL STATION
FINISH: #4 STN\STL
BOX DEPTH 3 1/2"
QUANTITY: 1

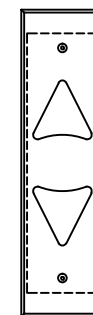

CAR LANTERN
FINISH: #4 STN\STL
BOX DEPTH 3 1/2"
QUANTITY: 1

REV NO.	BY	DESCRIPTION	DATE
1	.	.	.
2	.	.	.
3	.	.	.
4	.	.	.
5	.	.	.

SWITCH LEGEND

KEY	TOG	IND	SWITCH	OPER. POSITIONS	KEY REM POS
1		A	FIREMAN	OFF-HOLD-ON	OFF-HOLD
2			STOP	RUN-STOP	ALL
3			LIGHT	ON-OFF	ALL
4			FAN (1 SPEED)	ON-OFF	ALL
5			FAN (2 SPEED)	LOW-OFF-HIGH	ALL
6			IND SERVICE	ON-OFF	ALL
7			INSPECTION	INSP-NORM	ALL
8			ACCESS ENABLE	ON-OFF	ALL
9			KEYED ON\OFF	ON-OFF	ALL

PUSHBUTTON LEGEND

10	CALL CANCEL
11	ALARM
12	PUSH TO CALL
13	DOOR OPEN
14	DOOR CLOSE
15	FRONT DOOR OPEN
16	FRONT DOOR CLOSE
17	REAR DOOR OPEN
18	REAR DOOR CLOSE

GENERAL LEGEND

19	COMPANY LOGO
20	CAPACITY
21	MULTI-LIGHT POSITION INDICATOR
22	DIGITAL POSITION INDICATOR
23	EMERGENCY LIGHT
24	SPEAKER PHONE
25	PHONE BOX
26	FIRE SERVICE INSTRUCTIONS
27	NO SMOKING
28	PUSH\PULL STOP BUTTON

American Crescent Elevator

THIS ARRANGEMENT AND SUPPLEMENTAL NOTES:

- APPROVED NO EXCEPTIONS
- APPROVED AS NOTED
- REVISE AND RESUBMIT

Signature _____

Date _____

The PRELIMINARY SHOP DRAWINGS are provided for your review & verification of specific features of the elevator & building. Equipment will be processed only AFTER these drawings are returned to American Crescent Elevator, with ALL information verified and all color selections are made, complete with signature. Actual ship dates from the factory will be confirmed to you after the approved prints are received. If you have any questions about any of the information or need assistance in completing your review, please contact: American Crescent at (601) 798-9392.

The FINAL SHOP DRAWINGS reflect all modifications/clarifications as indicated on the Preliminary Drawings and should be referenced carefully during construction and preparation for elevator installation. Any deviation from the information or dimensions contained herein could have a serious effect on the elevator installation and/or operation of the elevator. Any increase of size or addition of items may be subject to a price adjustment and can contribute to a longer lead time on equipment.

PROJECT:	Lakeshore Baptist
JOB NO.:	9392-XXXX
DESCRIPTION:	SIGNAL FIXTURES LAYOUT
Drawn By	ACP
Scale	N.T.S.
Date	10/25/2013
Sheet	4 OF 4